

Portable Whirlpool Spa

Owner's Manual

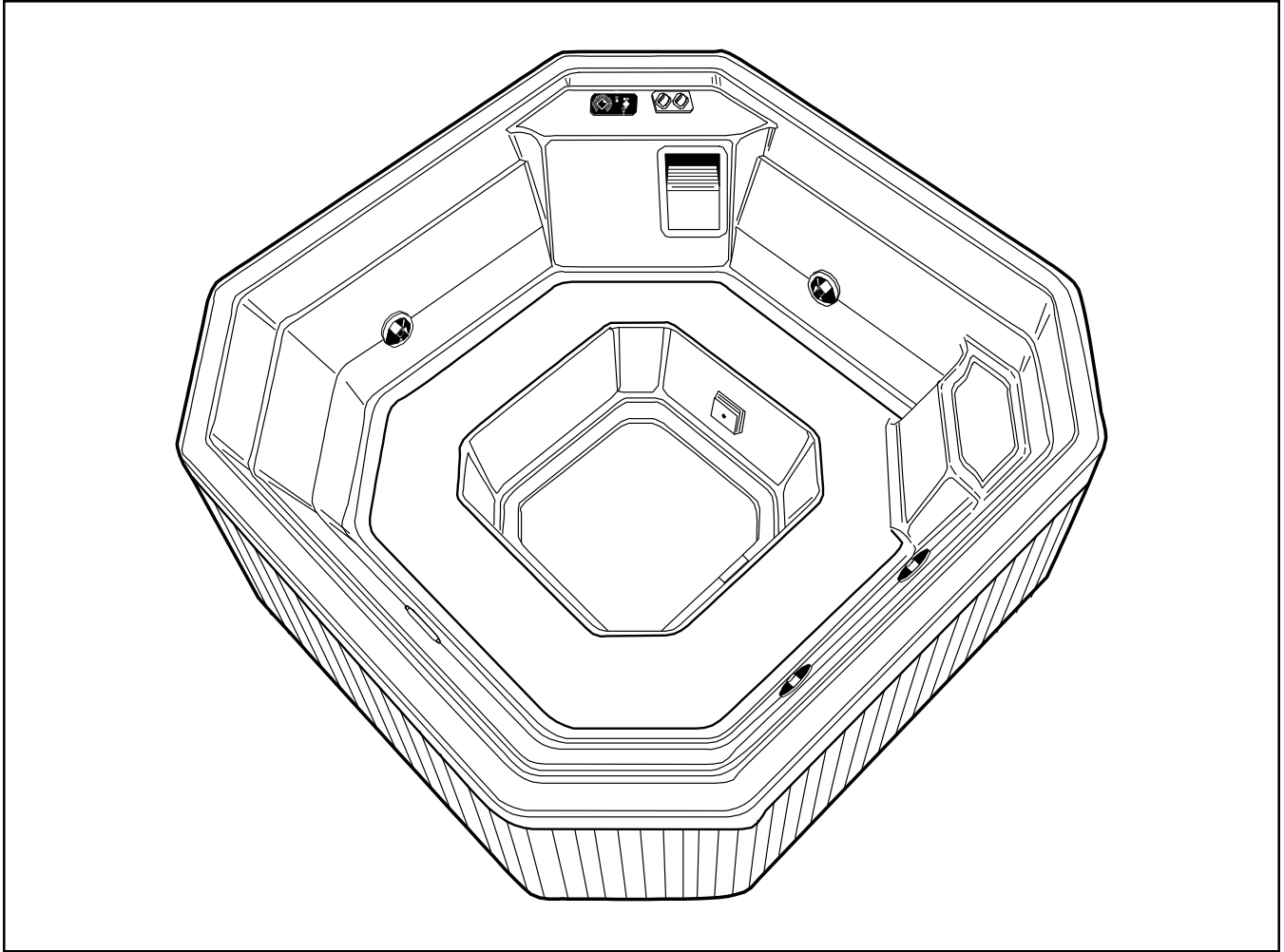

IMPORTANT SAFETY INFORMATION

READ AND FOLLOW ALL INSTRUCTIONS

Warning — Risk of injury: Children, the elderly, and the infirm should not use the spa unless they are supervised at all times. Infants should not be permitted in the spa at water temperatures over 100° F (38°C).

Spa water temperatures in excess of 104° F is not recommended. High water temperatures in excess of 104° F (40° C) and prolonged periods of use can raise internal human body temperature excessively and impair the body's ability to regulate its internal temperature.

Pregnant women and people with heart circulatory conditions, or diabetes, should consult their physicians before using the spa at water temperatures over 100° F (38° C).

Limit your initial use of the spa to 10 - 15 minutes. High body temperatures affect people differently; consult your physician about your safety and comfort before using the spa.

If your spa product does not have a thermometer, we recommend that you use a medical (clinical) type thermometer for an accurate measurement of spa water temperatures. Other types of thermometers, generally available, such as those used for swimming pools are not sufficiently accurate to determine spa water temperatures.

Extra care should be taken when using the spa and consuming alcoholic beverages. Alcohol, drugs, or certain medications, such as tranquilizers, affect a person's ability to withstand high temperatures and may produce dangerous effects, including drowning. Persons using medication should consult with a physician before using a spa.

Danger — Risk of injury: Do not remove the suction grille! It is a safety device and must always be in place on the suction fitting to minimize the potential hazard of hair entanglement or body entrapment.

Keep body, hair, and clothing a minimum of 12 inches away from suction fitting and skimmers at all times when the spa is operating. Hair longer than shoulder length should be secured close to the head, or a bathing cap should be worn.

Do not operate the spa if the suction cover is broken or missing. Contact your Dealer for replacement cover if broken or missing.

The wet surface of the spa is slippery. Use care when entering and exiting.

DANGER — Risk of child drowning: Do not permit children to use this product unless they are closely supervised. The use of a locked cover is highly recommended to prevent unattended access.

DANGER — RISK OF ELECTRICAL SHOCK: When installing and operating this electrical equipment, basic safety precautions should always be adhered to including the following.

Warning: A wire connector is provided at the electrical cabinet on this spa to connect a minimum No. 8 AWG (8.4 MM²) solid copper conductor between this spa and any metal equipment, metal enclosures of electrical equipment, metal water pipe, or conduit within 5 feet (1.5 m) of the spa.

Do not use electrically connected devices such as television, radio, or stereo speakers, lights, cooking devices, or telephones within 5 feet (1.5 m) of the spa while the spa is being used. Lighting fixtures must not be located directly above or within 5 feet (1.5 m) of the spa. If located within 10 feet (3.0 m) of the spa, they must be on a circuit protected by a GFCI (Ground Fault Interrupter Circuit).

All fixed metal objects located within 5 feet of the spa, such as fence posts, railings, door frames, greenhouse structures, gutters, etc., must be attached to the bonding bar on the outside of the spa electrical cabinet using #8 solid copper wire. **With #8 solid copper wire, bond the spa to the house electrical panel or approved local bond.**

The spa must be installed with adequate access and water drainage system, refer to Installation Instructions, to drain water away from electrical components.

CAUTION: Do not turn power ON to the spa unless it is filled with water to the normal water level, which is to the water level indicator mark on the skimmer frame. Activating the spa when there is an insufficient amount of water can damage the circulation pump and may cause a fire.

If your spa is installed in a 230VAC circuit:

DANGER — RISK OF ELECTRICAL SHOCK

Your spa must be equipped with a GFCI at the Main Electrical Panel. At initial start-up and before each use thereafter with power ON, push the GFCI test button. The reset button should pop out. Push this button in to reset. If the interrupter fails to operate in this manner, there is a ground current flowing or a device malfunctioning, indicating the possibility of electrical shock. **Turn off power and do not use the spa until the source of the problem has been identified and corrected.**

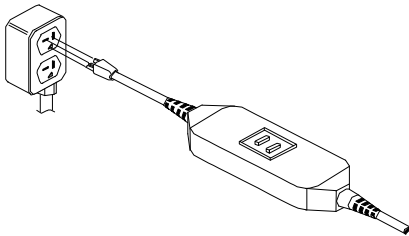

If your spa is installed in a 115VAC, 20 AMP circuit:

1. The spa is supplied with a 15 foot line cord which terminates with an integral GFCI plug. Locate the spa near enough to a weather protected outlet, but no closer than 10 feet. **DO NOT USE AN EXTENSION CORD!** Using an extension cord is hazardous and will decrease the amount of power to the unit, causing slow heating, poor whirlpool performance, or system malfunction.

2. Replace damaged line cord immediately. Do not bury line cord. Connect to a grounded, grounding type receptacle only.

3. Bring the line cord out from under the skirt. Remove skirt screws as required to gain access. Make sure the line cord does not lie across a walkway or in a heavily traveled area where it may be a safety hazard or become damaged.

4. At initial start-up and before each use thereafter with power ON, push the GFCI test button. The reset button should pop out. Push this button in to reset. If the interrupter fails to operate in this manner, there is a ground current flowing or a device malfunctioning, indicating the possibility of electrical shock. **Turn off power and do not use the spa until the source of the breakdown has been identified and corrected.**

www.clearcreeks spas.com

Read manufacturer's safety information provided with all optional equipment.

Whirlpool Spa OWNER'S MANUAL

Contents

Installation	2
Inspection and Shipping Claim	2
Positioning Your Spa	2
Electrical Requirements and Precautions for:	
Spa with 120VAC, 20 AMP GFCI Line Cord	3
Spa Designed for 230VAC Circuit	4
Outdoor Installation	5
Drainage	5
Indoor Installations	5
Equipment Set-Up	6
Operation	7
Operating Instructions	7
Control Panel	8
Normal Operation/Whirlpool System	9
Silent Air Induction	9
Maintenance	10
Water Quality and Water Chemistry	10
Filtration	10
Water Chemistry	10
Disinfecting	11
Balancing pH	11
Balancing Total Alkalinity	11
Water Quality Definitions	11
Water Level/Drain	12
Skimmer Basket Maintenance	12
Filter Maintenance	12
Automatic Filtration/Maintenance	13
Winterizing	13
Factory Installed Redwood Skirt	13
Spa Light	14
Cleaning Your Spa	14
Covering Your Spa	14
Repairs to the Acrylic	14
Troubleshooting Guide	15

Owner's Record

Date Purchased _____
Purchased From _____
Installed By _____
Spa Serial Number _____ Model # _____

INSTALLATION

Inspection and Shipping Claim

Check for shipping damage upon receipt of the spa. Jacuzzi Whirlpool Bath is not responsible for damage to the spa sustained during shipping. If damage is evident before unpacking, refer to instructions regarding shipping claims on the outside of the carton and immediately file a claim with the carrier.

Once the spa has been removed from the carton and before it is permanently installed, check the spa completely for damage. Fill the shell with water and operate the system (refer to Operating Instructions) to check for leaks which may have resulted from improper shipment or handling. All Jacuzzi Whirlpool Bath spas are factory tested for proper operation and water tight connections prior to shipment. If leaks or other problems are detected, immediately notify your Jacuzzi Whirlpool Bath dealer, Authorized Service Agent, or call Jacuzzi Whirlpool Bath, (510) 938-7411, or (510) 938-7070 for Warranty Service.

NOTE: Damage or defects which could have been discovered and repaired prior to installation and which are claimed after final installation of the spa, are excluded from our warranty.

Positioning Your Spa

Because your spa is a portable, you can locate it just about anywhere you wish—on a deck, patio, or even indoors. Just be sure to position it above ground in an area with good drainage and on a level, continuous surface which can support the weight of the spa when filled with water and people. You must also provide access to the spa's equipment for service and general maintenance. See specifications sheet for minimum service access requirements.

Your spa, as it comes from the factory, has either a 115 VAC GFCI equipped line cord (see page 3), or is designed for a 230 VAC circuit (see page 4).

INSTALLATION

SPA WITH 115 VAC, 20 AMP GFCI LINE CORD

Electrical Requirements

Your spa, as it comes from the factory, requires a 115 VAC, 20 AMP electrical outlet and must be in a grounded separate circuit having no other appliance connected in that circuit. If you do not have a 115 VAC, 20 AMP circuit, a qualified electrician should be called in to install the necessary wiring. Inadequately sized wiring may cause the unit to malfunction and bring about permanent damage to the spa's electrical system. The circuit must also have a ground wire in order to take advantage of the designed-in safety features of the spa. A bond wire must also be used. Bond according to procedure described on page 5.

Warning: Without proper grounding and bonding, a system malfunction may cause fatal shock.

Electrical Precautions

1. The spa is supplied with a 15 foot line cord which terminates with an integral Ground Fault Circuit Interrupter (GFCI) plug; locate the spa near enough to a weather protected outlet, but no closer than 10 feet. **DO NOT USE AN EXTENSION CORD!** Using an extension cord is hazardous and will decrease the amount of power to the unit, causing slow heating, poor whirlpool performance, or system malfunction.
2. Bring the line cord out from under the skirt. Remove skirt screws as required to gain access.

Make sure the line cord does not lie across a walkway or in a heavily traveled area where it may be a safety hazard or become damaged.
3. Do not locate lighting fixtures directly above the spa. If lighting is located within 5 feet of the spa, it must be on a circuit protected by a GFCI (Ground Fault Circuit Interrupter).
4. Do not use electrically connected devices, such as television, radio, telephones, stereo speakers, lights or cooking devices within 5 feet of the spa while the spa is being used.
5. All fixed metal objects located within 5 feet of the spa, such as fence posts, railings, door frames, greenhouse structures, gutters, etc., must be attached to the bonding bar on the outside of the spa System Control Module using #8 solid copper wire. **With #8 solid copper wire, bond the spa to the house electrical panel or approved local bond. Bonding lugs are available at your local electrical supply store. (See illustration on page 5 for bond bar location.)**
6. An approved ground may be an 8 foot long ground rod, a plate electrode, or a buried metal water pipe with at least 10 feet of buried pipe. Check your local building code for requirements.

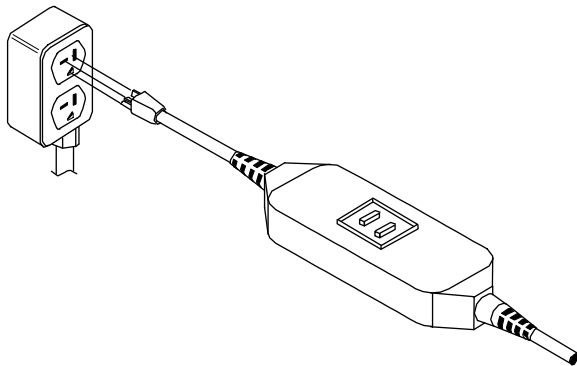

WARNING!

The continuous service ground wire is located in the line cord supplied. Do not modify this cord in any way! Tampering with the ground wire or using an adaptor which would make the built-in grounding device and GFCI ineffective would cause electrical shock. Such modification would also nullify the warranty.

CAUTION: Do not plug in the spa unless it is filled with water to the normal water level, which is approx. 7" below the spa rim. If the spa's motor/pump is actuated when there is not sufficient water in the unit, the circulation pump could be irreparably damaged. Not heeding this caution will nullify the warranty. In addition to damaging the unit, operating the unit with insufficient water could cause a fire.

INSTALLATION

SPA DESIGNED FOR 230VAC CIRCUIT

Electrical Requirements

Your spa requires a 230 VAC, 50 AMP, 4-wire, grounded type GFCI protected electrical service with copper conductors, and must be in a separate circuit having no other appliance connected in that circuit. If you do not have this kind of circuit, a qualified electrician should install the necessary wiring. Inadequately sized wiring may cause the unit to malfunction and bring about permanent damage to the spa's electrical system. The circuit must also have a ground wire in order to take advantage of the designed-in safety features of the spa. A bond wire must also be used. Bond according to procedure described on the next page.

WARNING: Without proper grounding and bonding, a system malfunction may cause fatal shock.

Electrical Precautions

CAUTION: Do NOT apply electrical power to the spa unless it is filled with water to the normal water level, which is approximately 7" below the spa rim (refer to location of water level indicator on face of skimmer). If the spa's motor/pumps are actuated when there is not sufficient water in the unit, the circulation pump could be irreparably damaged. Not heeding this caution will nullify the warranty. In addition to damaging the unit, operating the unit with insufficient water could cause a fire.

Do NOT locate lighting fixtures directly above the spa; lighting and electrical receptacles must be located at least 5 feet from the spa. Lighting located between 5 and 10 feet from the spa must be on a circuit protected by a GFCI. (Refer to National Electrical Code, 680-6.)

Do NOT use electrically connected devices, such as television, radio, telephones, stereo speakers, light or cooking devices within 5 feet of the spa when the spa is being used.

All fixed metal objects located within 5 feet of the spa, such as fence posts, railings, door frames, greenhouse structures, gutters, etc., must be attached to the bonding bar on the outside of the spa electrical cabinet using #8 solid copper wire. **With #8 solid copper wire, bond the spa to the house electrical panel or approved local bond.**

An approved ground may be an 8 foot long ground rod, a plate electrode, or a buried metal water pipe with at least 10 feet of buried pipe. Check your local building code for requirements. Bonding lugs are available at your local electrical supply store. (Bond bar location is shown on page 5.)

INSTALLATION

Outdoor Installation

If you install the spa outdoors, we recommend that you provide a concrete pad for it to rest on. To do this, construct forms for a 4" thick level pad. Install a #10 gauge wire mesh 6" x 6" steel reinforced grid. Attach a #8 solid copper wire to the grid with a ground clamp. This wire should be long enough to reach the bond bar on the spa electrical cabinet (minimum 36"), but should **not** be located under the base of the spa. Then pour the concrete pad.

Drainage

Whether you install your spa indoors or outdoors, you can drain it completely by attaching a garden hose to the hose bibb (drain valve) located on the suction plumbing of the spa. Simply run the hose to the house sewer line or drain field and open the hose bibb.

Make sure the area surrounding the spa has good drainage to keep water from collecting at the base of the spa—especially near the equipment area. If drainage is poor, install a drain line and/or gravel drain field. (Refer to illustration below.)

Indoor Installation

Water that splashes on the floor during spa use may cause a walking hazard and/or structural damage. Good drainage must be provided and proper waterproof building materials must be used in the area surrounding and beneath the spa. Take into consideration that high room humidity will exist due to high spa water temperatures. Providing natural or forced ventilation of the room will help maintain comfort and minimize moisture damage to the building. Jacuzzi Whirlpool Bath is not responsible for damages resulting from excess moisture or water spillage. Consult an architect or engineer for aid in designing your indoor installation.

SUPPORT, DRAINAGE AND BONDING

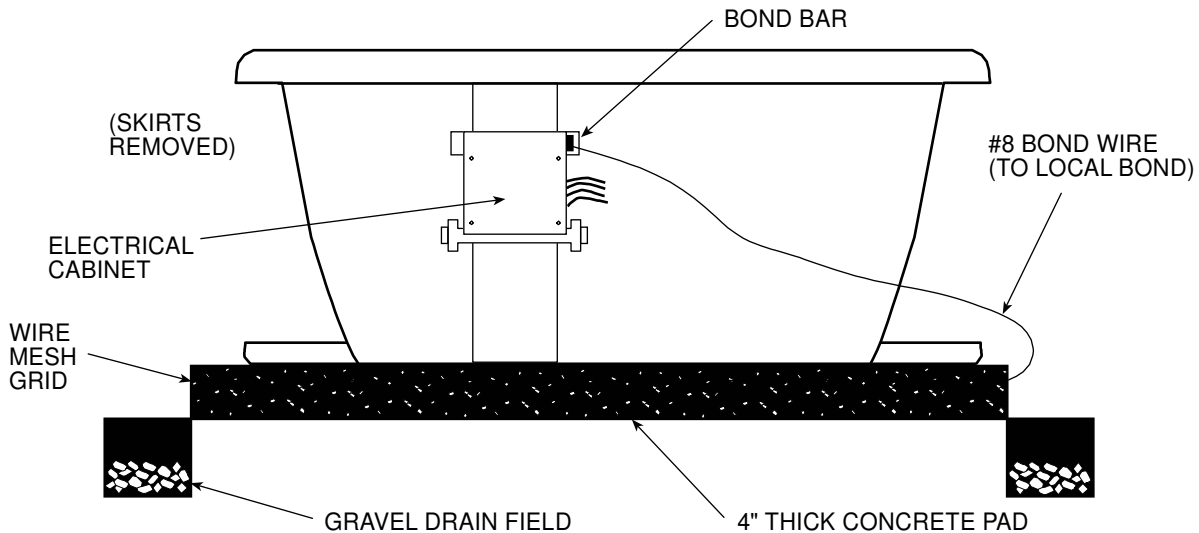

INSTALLATION

Equipment Set-Up

1. Remove the plastic sheet covering the spa.

NOTE: Stepping into the spa with shoes will scratch the acrylic surface.

2. Remove any packing materials from the spa.
3. Remove the filter cartridge from its plastic bag.
4. Pull open the skimmer/filter door by the handle located in the middle of the door and remove the skimmer basket. Then insert the filter cartridge into the filter housing and reinsert the basket so that it fits in place over the filter cartridge and close the skimmer/filter door.
5. Clean the interior of the spa of any remaining construction debris. Remove stubborn stains, paint, or tar with turpentine, isopropyl alcohol or paint thinner. A mild liquid dishwashing detergent on a damp cloth is fine for cleaning off other dirt. Plaster can be removed by scraping with a soft plastic or wooden edge. Do not use a metal scraper, wire brush, or other metal tools, as they will damage the spa's surface.
6. Install the skirt panels which were not installed on the spa at the factory. Use the screws provided in your spa accessory package and follow instructions provided with the panels.
7. On initial start-up, it is necessary to purge and sanitize the system as stated below.
 - Remove the spa cover completely.
 - Close the drain valve on the suction plumbing.
 - Open the adjustable jets.
 - Fill the spa with water to its normal operating level, which is to the water level indicator mark on the skimmer/filter frame.

- Turn ON the circuit breakers at the main electrical panel.
- At the control panel on the spa rim, press the jets button three times for high speed pump operation.
- Add 1/4 cup sodium dichlor (a fast dissolving granular type of chlorine) to the water and run for 15 minutes.
- Turn OFF the circuit breakers.
- **Immediately** open the drain valve and drain the spa completely.

CAUTION: Leave the optional cover OFF the spa during this procedure. DO NOT use the spa during this procedure. Drain the spa immediately afterward.

8. Close the drain valve and fill the spa with water (approximately 7 inches below the spa rim) to the water line indicator mark on the skimmer frame.
9. Turn ON circuit breakers at the main panel.
10. Test the spa for proper operation. (Refer to Operating Instructions.)
11. Refer to Water Quality section of the Operating Instructions. Test for water quality and then add treatment chemicals as necessary to ensure proper water quality levels.

All Jacuzzi Whirlpool Bath spas are factory tested for proper operation and water tight connections prior to shipment. If leaks or other malfunctions are detected, immediately notify your Jacuzzi Whirlpool Bath dealer, Authorized Service Agent, or call Jacuzzi Whirlpool Bath, (510) 938-7411 or (510) 938-7070 for Warranty Service.

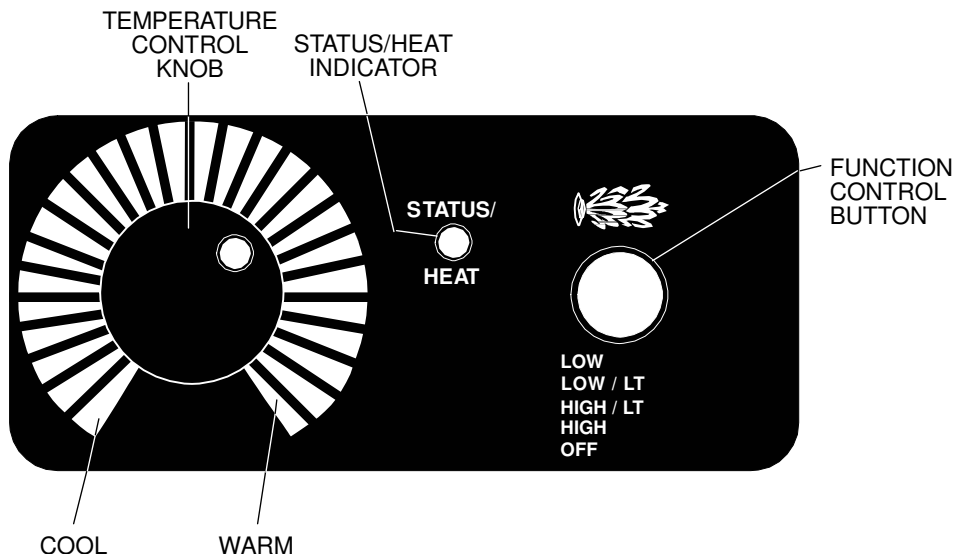

OPERATION

Operating Instructions

Now that the spa is in place, you are probably eager to take advantage of its unique designed-in features—especially the patented hydromassage performance. Besides being a beautiful addition to your indoor decor or outdoor landscaping, your Jacuzzi Whirlpool Bath spa will provide you with the ultimate in spa pleasure.

Familiarize yourself with the operation of the electronic control panel, as described on page 8 of this manual. Access under the spa (behind the skirts) is not required for normal operation.

WARNING: Do not turn ON power to the spa unless it is filled with water to the normal water level. (Refer to water line indicator mark on skimmer frame.) Whenever the power is ON, the system may activate even though no controls are operated. If the spa's motor/pump is actuated when there is not sufficient water in the unit, the circulation pump and heater could be irreparably damaged. Not heeding this caution will nullify the warranty. In addition to damaging the unit, operating the spa with insufficient water could cause a fire.

Initial Instructions

Using a garden hose, fill the spa with water to the water line indicator mark on the skimmer frame. (Refer to page 9 for information on using the Water Rainbow spout if desired.)

At the house service panel, turn ON the circuit breaker or switch that controls the electrical service to your spa. (Make sure there is no other appliance on that circuit.)

Spa with 115VAC, 20 AMP GFCI Line Cord.

Your spa is provided with a Ground Fault Circuit Interrupter (GFCI) on the line cord. At initial start-up and before each use thereafter, with power on, push test button on the GFCI. The reset button should pop out. Push this button in to reset. If the interrupter fails to operate in this manner, there is a ground current flowing or a device malfunctioning, indicating the possibility of electric shock. **Turn OFF power and do not use the spa until the source of the problem has been identified and corrected.**

Spa Designed for 230VAC Circuit

Your spa must be installed in an electrical circuit protected with a ground fault circuit interrupter (GFCI) (refer to Electrical Requirements). At initial start-up and before each use thereafter, with power ON, push the GFCI test button. The reset button should pop out. Push this button in to reset. If the interrupter fails to operate in this manner, there is a ground current flowing or a device malfunctioning, indicating the possibility of electric shock.

DANGER: Turn OFF power and do not use the spa until the source of the problem has been identified and corrected.

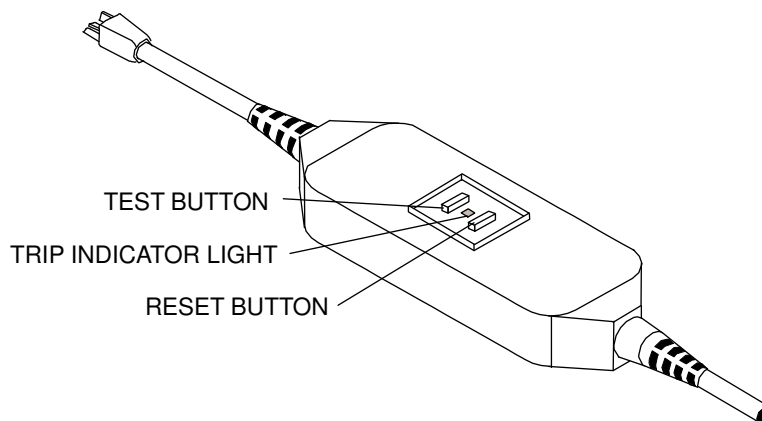

OPERATION

The spa will automatically begin to operate when electrical power is applied. There is no ON/OFF switch for the spa system.

The control system has been designed so that by connecting the spa to its properly grounded power source, it will begin to operate. The Status/Heat LED will light briefly. The pump will activate if the temperature of the water is less than 65°F.

Control Panel

The Control Panel is easy to use with fingertip control of all the spa functions.

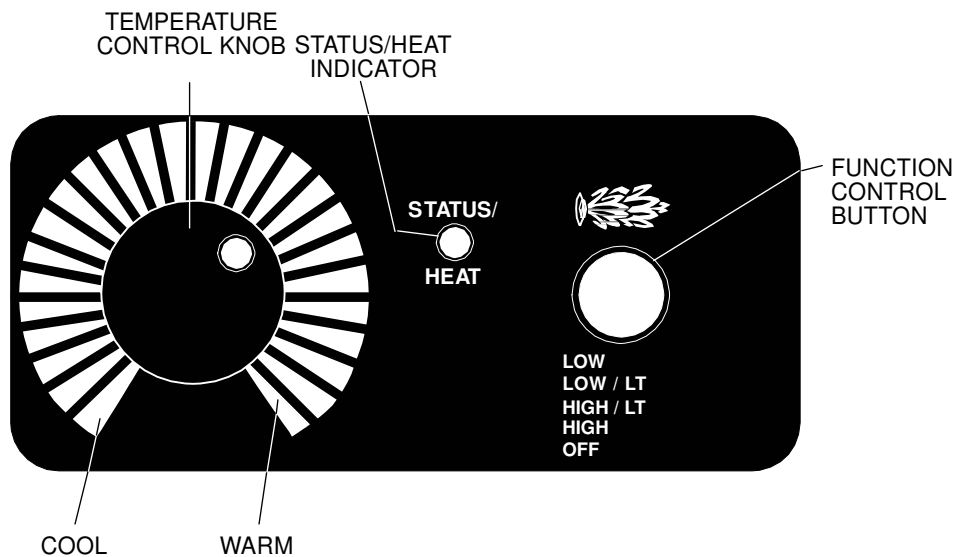

Temperature Control

To increase the temperature, turn the Temperature Control Knob clockwise to the desired setting. To reduce the temperature, turn the knob counter clockwise.

Function Control Button

Press the Function Control Button once and the low speed pump will operate. Press the button again and both the low speed pump and spa light will operate. Press the button a third time and the high speed pump and spa light will operate. Press the button a fourth time and the high speed pump will operate without the light. Push the button again and the system will turn off.

Filter Cycles

Your spa will automatically filter itself twice a day. During filtration, the low speed pump will activate. The first filter cycle will begin one hour after the spa has been energized. The second cycle will begin twelve hours after the start of the first cycle.

Over Heat Protection

In the event the spa should overheat, the Status/Heat LED will flash and the spa will shut down. If this situation occurs, turn off all power to the spa and contact your dealer or service organization. To reset the spa, press the Function Control Button.

Flow Switch Detection

If the pressure switch malfunctions, the Status/Heat LED will flash. If this situation occurs, turn off all power to the spa and contact your dealer or service organization.

Open Sensor

If either the high limit or water temperature sensors malfunction, the Status/Heat LED will flash. If this situation occurs, turn off all power to the spa and contact your dealer or service organization.

OPERATION

Normal Operation/Whirlpool System

You can enjoy the spa with or without activating the whirlpool. Either way, bathing in your spa can be pleasurable, as well as therapeutic. After a busy, stressful day, you can look forward to soaking in your spa in still water with no turbulence—only the gentle warmth of the soothing and relaxing water.

For a more invigorating spa experience, you can take advantage of the built-in whirlpool system. To do this, press the JETS button for low or high speed JETS. Sit or recline in the spa so you are comfortable. Since all the jets are directionally adjustable, you can direct a jet toward an area where muscles feels tense or stiff. The warmth of the water and the stimulating water flow from the jets will pleasantly increase circulation.

For the total whirlpool effect and all over feeling of well being, you can adjust all jets so they point in a clockwise or counterclockwise direction to circulate the air and water mixture in a circular motion all about the spa.

Silent Air Induction

The intensity of the whirlpool action is determined by how much air is induced into the water. You control this by adjusting the air induction control knobs located on spa rim. For maximum air induction, rotate each control knob fully counter clockwise to the largest circle. For fewer air bubbles, decrease the amount of air induction by rotating the control knobs clockwise. When the knobs are turned to the smallest circles, only water is being circulated.

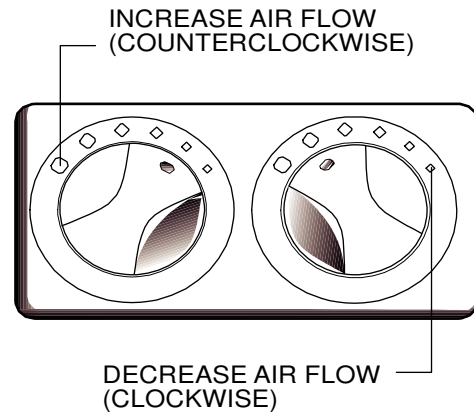

DIRECTIONALLY ADJUSTABLE WHIRLPOOL JETS

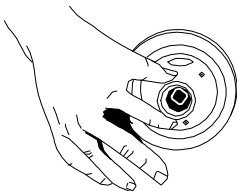

FULLY ADJUSTABLE WHIRLPOOL JETS

AIR INDUCTION CONTROLS

MAINTENANCE

Water Quality and Water Chemistry

Maintaining water quality and water chemistry in your spa is extremely important and should be a regular part of your spa maintenance program, as a neglected spa can be a breeding place for dangerous bacteria.

The water quality of your spa is maintained by a combination of filtration and chemistry. The spa's integral filter system helps maintain the water cleanliness and clarity by trapping most solid materials such as hair, and other debris resulting from normal use. However, the most important part of maintaining water chemistry is keeping the proper level of disinfectant in the water at all times. This is accomplished by adding chlorine or bromine to the water, which will control particles too small to be trapped by the filter, such as bacteria and algae, and will oxidize any organic materials. Follow instructions provided here and with water quality products for the health and safety of spa users, as well as to make your spa bathing as enjoyable as possible.

Filtration

The filtration system of your spa will keep your water clear and clean if used properly. The filter cartridge elements will trap most solid materials and debris in the water. However, the presence of materials such as body oils or other particles which are too small to be captured in the filters may bring about various undesirable water quality conditions. These conditions can be corrected with the use of spa treatment chemicals which are available from your Jacuzzi Whirlpool Bath dealer. Such conditions include the following:

Foaming: A defoamer is available to minimize foaming of the water. This condition is usually caused by the addition of soaps or oils, or other fatty substances to the spa water. The interaction of these with hot water, especially at high pH (more alkaline), will cause the water to foam. (Refer to Water Quality Definitions.)

Oil Film or Cloudy Water: Add clarifier to congeal oil film on the water surface into globules sufficiently large to be trapped by the system's filter. Cloudiness is caused by particles that are too small to be trapped in the filter, and is also due to the presence of human body oils, lotions, and cosmetics. During normal use, these materials can accumulate on the filter element and clog its pores. The addition of clarifier will make the water clearer, but clogged filters must be cleaned as prescribed under the section entitled Filter Maintenance in this manual.

Hard Water: Add a demineralizer to break down or deionize mineral particles present in the spa water.

Follow the Filter Maintenance procedure described in this manual to ensure optimum performance of your spa's filtration system.

Water Chemistry

You can ensure better water chemistry by testing your spa water every day and adjusting the chemical balance frequently. Obtain a water quality test kit, designed especially for spas, from your Jacuzzi Whirlpool Bath dealer. The test kit must be of the type which allows you to test for the disinfectant (chlorine) level, pH, and total alkalinity. Ensure that the chemicals used in your spa are especially for spa use, and not for swimming pools, as water quality maintenance of spas and of swimming pools is very different.

Set up a daily program at first to check the disinfectant level, pH, and total alkalinity of the water. Familiarize yourself with the amount of chemicals to add and to determine how often to make chemical adjustments during normal use. Remember that the more heavily the spa is used, the more often you should check the water chemistry.

When adding any chemicals, always run the filter system to ensure complete dilution with the water. **Do not add chemicals directly into the skimmer.**

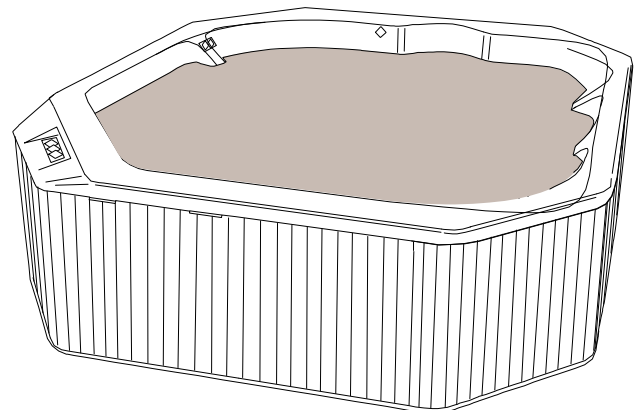

MAINTENANCE

Water Chemistry (Continued)

Disinfecting

When filling the spa for the first time, follow the purge/sanitizing instructions in the Equipment Set-Up procedure of the Installation Instructions.

Add a disinfectant to the water on a regular basis to help control the amount of bacteria, algae and organic materials. Such bacterial contaminants, if not controlled, could cause skin rashes or other physical problems. To disinfect the spa for normal use, first establish the amount of chlorine or bromine to add and determine how often you need to add it.

We recommend that you maintain a free chlorine level of 2.0-5.0 ppm at all times except when you must exceed that during the initial purge/sanitizing procedure or during superchlorination (refer to Water Quality Definitions below). Superchlorinate your spa every two weeks with heavy use. If using sodium dichlor, add one heaping tablespoon for each 150 gallons of spa water. Scrub the spa surfaces with this solution to remove any oily deposits. This will ensure that any bacteria or algae which are resistant to the normal disinfectant level are killed. After adding the disinfectant, run the filter system and allow the free chlorine level to return to the 2.0 to 5.0 ppm range before using the spa again. **Do not install a cover until the disinfectant level is back to normal. High concentrations of chlorine or bromine will damage metallic plated finishes if the cover is in place.**

Balancing pH

For good hygiene and equipment longevity, maintain the pH of your spa water according to the instructions provided. pH is the measure to determine if the spa water is too acid (low pH, or too alkaline, or basic high pH). The ideal range for spa water is 7.2 to 7.6 pH. For excessive acidity (below 7.2 pH) add soda ash or sodium bicarbonate to the spa water. For excessive alkalinity (above 7.6 pH) add dry acid to the spa water.

Caution: Refer to the spa chemical manufacturer's instructions for the initial amount of chemicals to add for the gallonage of your spa. Low pH can cause equipment damage, as acid water will dissolve metals, while high pH can cause scale or calcium deposits to build up in the system or on the shell. After adding chemicals, run the filter system for at least 30 minutes before testing water quality again for accurate readings.

Balancing Total Alkalinity

Total alkalinity is the measure of base materials in the water. The recommended range for total alkalinity is between 80 ppm and 150 ppm. If the chemistry of the water is not within this range, you will have difficulty adjusting your pH level, which will affect your adjustments for the proper amount of free available chlorine. If the alkalinity of your spa water is high, it is advisable to drain the water from the spa and begin the balancing process over again. Purge and sanitize your spa (according to instructions in Equipment Set-Up section of the Installation Instructions) and clean the spa surfaces thoroughly before refilling with fresh water. Then reestablish water chemistry. If the spa is used heavily, change the water at least every month.

WATER QUALITY DEFINITIONS

pH: A chemical term used in expressing relative acidity or alkalinity in numeric values with 7.0 usually regarded as neutral, and for purposes of this manual, indicating pure water. From 7 to 0 indicates increasing acidity, and 7 to 14 indicates alkalinity.

PPM: Parts per million.

Free Chlorine: Chlorine that has not combined with other chemicals and that is available to destroy bacteria in the spa water.

Trichlor: A form of chlorine used in pool or spa water treatment; usually supplied in tablet form. Not recommended because of its higher acidic nature and slow dissolving action. Prolonged contact with the spa shell may bleach or permanently mark the shell.

Sodium dichlor: The type of chlorine that is recommended for spa use, as it is available in fast dissolving granular form. It is neither excessively acid nor alkaline in character and does not readily dissipate in higher water temperatures.

Calcium Hypochlorite: A granular chlorine product that is inexpensive and effective but not recommended because it often tends to form calcium deposits on heater parts and plumbing fittings and leaves an unattractive film on the spa at the water line.

Sodium Hypochlorite: A liquid chlorine product that is inexpensive and effective but not recommended because the liquid is readily spilled onto the spa or a surrounding area, causing permanent damage.

Total Alkalinity: The measure of the amount of alkaline materials (such as carbonates, bicarbonates and hydroxides) in the water. High alkalinity inhibits the effectiveness of chemicals to change the pH. If the alkalinity of your spa water is high (above 150 ppm), it is advisable to drain the water from the spa and begin the balancing process over again. Low total alkalinity (below 60 ppm) could be corrosive and damage your spa system.

Superchlorination: (Also referred to as shock treatment.) The addition of an above-normal level of disinfectant to kill any bacteria or algae that might have become resistant to normal levels of disinfectant.

MAINTENANCE

Water Level/Drain

The water level in the spa must be maintained at its normal level. Evaporation and splashing will cause the water level to drop.

When concentrations of impurities from evaporation, water quality chemicals, body oils, perfumes, dirty feet, and winds, etc., accumulate in the spa and cannot be filtered out, it is necessary to drain your spa and refill it with fresh water. This should be done every 2 months or more often depending on the amount of use.

To drain the spa, turn OFF circuit breakers at the main electrical panel. Connect a garden hose to the drain valve in the suction plumbing, via access hole in the pan. Turn the handle and drain the spa.

After draining the spa, clean the spa shell, suction cover, skimmer, and filter, then close the drain valve and refill the spa with fresh water. Check the pH level and maintain water quality.

NORMAL WATER LEVEL

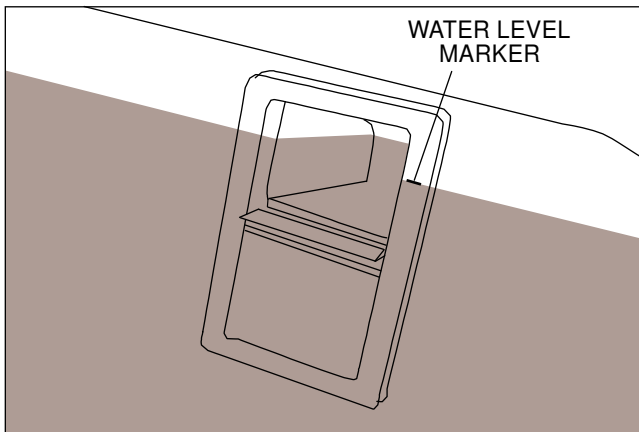

The suction cover located in the foot well area should be checked at least once a week for collected debris, such as leaves, hair, etc., and cleaned as necessary. It may not be necessary to remove the suction cover to clean it, but if you need to, remove the center screw with a Phillips screwdriver and clean the cover by flushing with water from a hose.

CAUTION: Be sure to replace the suction cover immediately after cleaning. It is a safety device and must be in place over the suction fitting to minimize potential hazard of hair and body entrapment.

If heavy rains raise the spa water level, drain the spa to its normal level.

A spa cover (available as an option), when in place over the spa, will help reduce evaporation and control the amount of debris entering the spa when the spa is not occupied. In addition, its use will reduce energy consumption.

Skimmer Basket Maintenance

The basket located in the skimmer of the spa should be checked at least once a week for collection of debris, such as leaves, hair, etc., and cleaned as necessary. To clean the basket, remove it from the skimmer by pulling it out, then backflush it with a garden hose and reinstall.

FRONT ACCESS SKIMMER/FILTER

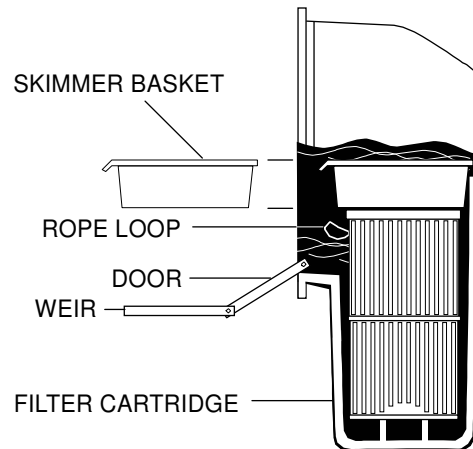

Filter Maintenance

The filter should be checked periodically. In normal use, check the filter at least once a month. Keep the filter clean. An obstructed filter reduces water quality and inhibits proper system performance.

A removable filter cartridge is located inside the skimmer. To remove it, pull open the skimmer door by the handle located in the middle of the door. Slide the basket out, then pull the filter cartridge upward and out of the housing by the loop at the top of the filter. Clean the filter by separating the folds of the filter and spraying with fresh water from a garden hose. Then reinstall the cartridge in the housing and replace the basket, reversing the above procedure.

Oils will coat the filter, resulting in a reduced flow. To remove such materials, soak the cartridge in a plastic pail containing a commercial filter cleaning solution (available from your Jacuzzi Whirlpool Bath dealer or most pool supply stores). Follow the manufacturer's instructions for use. Another method is to soak the filter cartridge in a plastic pail containing a mild solution of trisodium phosphate (TSP) and water. An hour of soaking time is usually required to break down oil coatings from the cartridge. Use a stronger solution of TSP and water to remove algae. Most hardware or paint stores stock TSP. Use the same method of cleaning when the cartridge becomes plugged with clay or vegetation. Replacement cartridges are available through your Jacuzzi Whirlpool Bath dealer.

MAINTENANCE

Automatic Filtration/Maintenance

If you plan to be away, minimum water quality will be maintained by running the filter system.

If you will be away for an extended period, however, we recommend that you drain the spa (following the procedure described under Winterizing on this page), as long periods without maintenance of water quality could be detrimental to the spa.

Another means of maintaining minimum water quality while away for less than two weeks is to follow the procedure outlined for winterizing your spa in a warm climate. (Refer to Winterizing.)

NOTE: We do not recommend using this procedure if you are absent during the summer, when algae buildup is most likely.

Always keep your spa covered when not in use to reduce heat loss and evaporation and to prevent debris from falling in.

Winterizing

In a climate where winter temperatures are below freezing, follow this procedure when the spa will NOT be used:

1. Turn OFF power to the unit at the main electric panel.
2. Drain the spa completely by attaching a garden hose to the drain valve on the suction plumbing. Then remove the hose and leave the drain valve open to completely drain the spa.
3. Remove, clean and store the filter cartridges, in a dry location.
4. Keep water and debris out by covering with a spa cover.

Before using the spa again, review the Operating Instructions.

In a warm climate where there are occasional freezing temperatures, your spa is automatically protected against freezing. Whenever water temperature falls below 65°F, the pump will come ON to circulate water.

Factory Installed Wooden Skirt

Your spa is supplied with a factory-installed stained wooden skirt which completely surrounds the spa. The door can be opened for maintenance.

If it becomes necessary to remove one or more of the skirt panels for major service access, simply remove the screws with which the section is secured.

To detach any of the panels, first remove all screws from the panel being detached.

The panels can be reattached to the spa by reversing the above procedure.

MAINTENANCE

Spa Light

Two filters, one blue and one red, are provided with your spa. To change the filter, simply snap the colored filters in place on top of the normal lens. Two replacement bulbs (GE#912, 12W, 12V) are also included. Put them in a safe place for future use. When a bulb burns out, replace it from the **back** of the light fitting on the outside of the shell by pulling out the bulb receptacle.

LIGHT BULB REPLACEMENT

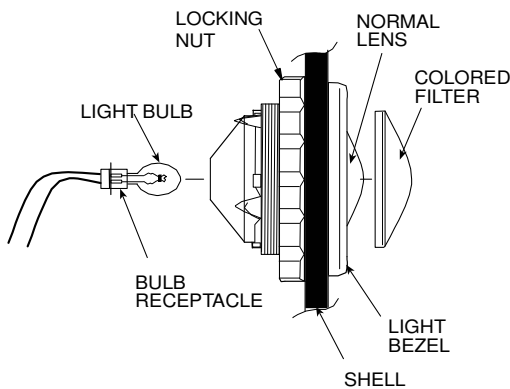

Cleaning Your Spa

Your spa shell consists of two layers of plastic materials. Its smooth top surface of acrylic is tough and durable and contains concentrated color. This is supported by a substantial thickness of fiberglass-reinforced polyester resin. A catalyst causes a chemical reaction during manufacture that bonds these layers permanently into a hard, strong material. With a minimum amount of care and cleaning, your whirlpool spa will look new for years.

To clean your spa, simply use a mild, nonabrasive liquid detergent, isopropyl alcohol, or commercially prepared spa cleaner. **Do not use abrasive cleaners.** You can protect and restore the gloss to a dulled surface by applying Meguiar's #10 Mirror Glaze, which is a product specifically designed for use on acrylic finishes. If Meguiar's is not available, an acrylic polish of equal quality or automotive paste wax will do.

Use a spa cleaner for residue buildup at the water level of the spa surface. This may be applied to the acrylic surface with a soft cloth and wiped clean. Use sparingly in small amounts to avoid contaminating the spa water. If the water line is heavily soiled, it may be advisable to lower the water level 2-3 inches before cleaning; then refill to normal level.

Covering Your Spa

An optional rigid spa cover for your spa is available from your Jacuzzi Whirlpool Bath dealer. Use of this cover will help to reduce energy costs by minimizing heat loss and evaporation. In addition, the attractive cover is an effective means of preventing debris such as leaves and dirt from entering your spa when not in use. Follow the instructions for use and care provided with the spa cover.

CAUTION: The spa cover is not designed to support any weight. Therefore, as a safety precaution and to preserve the life of your cover, you must not sit, stand, or lie on it; nor should you place objects of any kind on top of it.

Jacuzzi Whirlpool Bath does not guarantee or warrant this cover. Refer to spa cover manufacturer's information provided with the cover.

SPA SHOWN WITH INSULATING COVER

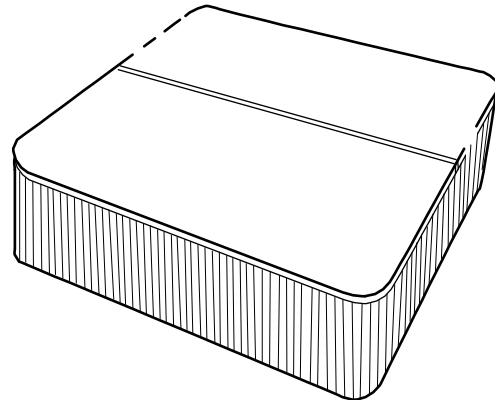

Repairs to the Acrylic

Minor scratches which do not penetrate the color finish (acrylic) can be removed with 600-grit wet/dry sandpaper. Restore the glossy finish with Meguiar's #10 Mirror Glaze or comparable automotive paste wax.

Major scratches or gouges which penetrate the acrylic surface will require refinishing. Ask your Jacuzzi Whirlpool Bath dealer for special instructions.

TROUBLESHOOTING GUIDE

PROBLEM	PROBABLE CAUSE	REMEDY
1. Water not clean.	<ul style="list-style-type: none"> A. Clogged or blocked suction strainer or skimmer basket. B. Filter clogged (dirty). C. Poor water chemistry. D. Insufficient filtering. E. Improper maintenance. F. High content of solids in water. G. Filter motor plug not connected to the electrical cabinet. 	<ul style="list-style-type: none"> A. Clean strainer/skimmer. B. Clean or replace filter. C. See Chemistry section. D. Increase daily filtering time. E. See Maintenance section. F. Use clarifier or drain and refill spa. G. Check filter motor connection on the electrical cabinet.
2. Abnormal water usage.	<ul style="list-style-type: none"> A. Leak in suction line, discharge line, or connections. B. Excessive evaporation and/or splashing. 	<ul style="list-style-type: none"> A. Repair leak. B. Use rigid spa cover; lower thermostat setting.
3. Low water flow from jets.	<ul style="list-style-type: none"> A. Normal operation in low speed jets, filter mode. B. Low water level. C. Clogged or blocked suction strainer or skimmer basket. D. Dirty filter. E. Adjustable jet partially closed. F. Suction or discharge line partially plugged. G. Pump running at subnormal speed. H. Worn or damaged pump seal. I. Subnormal voltage. 	<ul style="list-style-type: none"> A. Select high speed jets mode for maximum flow. B. Fill to water level indicator mark on skimmer/filter frame. C. Clean strainers or skimmer baskets. D. Clean or replace. E. Open jet. F. * G. * H. * I. Call an electrician or your power company.
4. No water flow from jets.	<ul style="list-style-type: none"> A. Power turned OFF. B. Pump OFF. C. Motor(s) not connected. D. House circuit breaker tripped; no power to system. E. GFCI tripped. F. Faulty pump or motor. 	<ul style="list-style-type: none"> A. Turn ON power at service panel. B. Select another function. C. Check motor plug connections on electrical cabinet. D. Reset circuit breaker. E. Reset GFCI. F. *

***Note:** The skills and tools necessary for the safe repair of this spa require the services of qualified service personnel. Contact your Jacuzzi Whirlpool Bath dealer.

TROUBLESHOOTING GUIDE

PROBLEM	PROBABLE CAUSE	REMEDY
5. Noisy pump and motor.	<ul style="list-style-type: none"> A. Clogged strainer(s). B. Leakage of air into suction line. C. Vibrating parts attached to motor or support brackets. D. Low water level. E. Damaged or worn motor bearings. F. Impeller rubbing inside case. G. Debris inside pump. 	<ul style="list-style-type: none"> A. Clean strainers B. Locate and repair leaks. C. Tighten fasteners. D. Add water to normal level. E. * F. * G. *
6. Water leakage at pump shaft (rotating connection between pump and motor).	<ul style="list-style-type: none"> A. Worn or damaged pump seal. 	<ul style="list-style-type: none"> A. *
7. Motor will not start.	<ul style="list-style-type: none"> A. Power OFF. B. House circuit breaker tripped or in OFF position. C. GFCI tripped. D. Subnormal voltage. E. Improper or defective wiring. F. Locked shaft or impeller. G. Motor windings burned out. H. Defective starting switch inside motor. 	<ul style="list-style-type: none"> A. Turn ON power at service panel. B. Reset circuit breaker. C. Reset GFCI. D. Call an electrician or your power company. E. * F. * G. * H. *
8. Motor stops.	<ul style="list-style-type: none"> A. Motor overload condition. B. Inadequate supply wiring. 	<ul style="list-style-type: none"> A. Let cool for one hour. Motor overload will reset; if problem persists, see *Note. B. Consult electrician to correct wiring to unit.

***Note:** The skills and tools necessary for the safe repair of this spa require the services of qualified service personnel. Contact your Jacuzzi Whirlpool Bath dealer.

**PRODUCT SPECIFICATIONS ARE SUBJECT TO CHANGE WITHOUT NOTICE.
USE INSTALLATION INSTRUCTIONS SUPPLIED WITH PRODUCT.**

Jacuzzi Whirlpool Bath has obtained applicable code (standards) listings generally available on a national basis for products of this type. It is the responsibility of the installer/owner to determine specific local code compliance prior to installation of this product. Jacuzzi Whirlpool Bath makes no representation or warranty regarding, and will not be responsible for any code compliance.

JACUZZI WHIRLPOOL BATH

Jacuzzi Whirlpool Bath National Headquarters
P.O. Drawer J, Walnut Creek, CA 94596 (510) 938-7070
Service Support: (800) 288-4002

